

SCREW: NONE	MATERIAL: COPPER	REV: I	 800-776-9775 www.ilSCO.com
CAT. NO.: SEE CHART	PLATING: EL-TIN	DRAWN BY:DW SCALE: NTS	
INFORMATION SHEET:FORM 157	MARKING: SEE CHART	DATE:7/5/2007 SIZE: B	
			DWG NO: Y1911-S SHEET: 1 OF 1

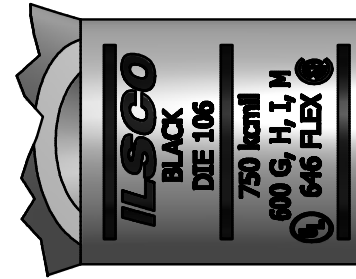

DETAIL B
TOP AND BOTTOM INK MARKINGS ARE IDENTICAL
INK COLOR: BLACK

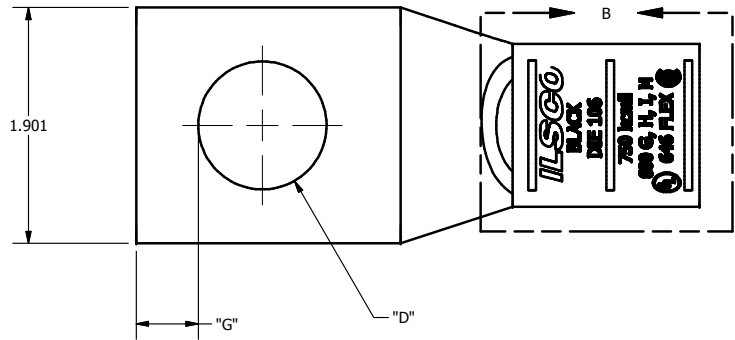
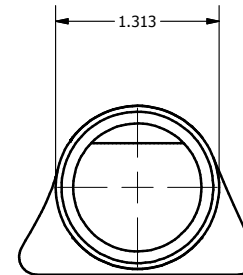
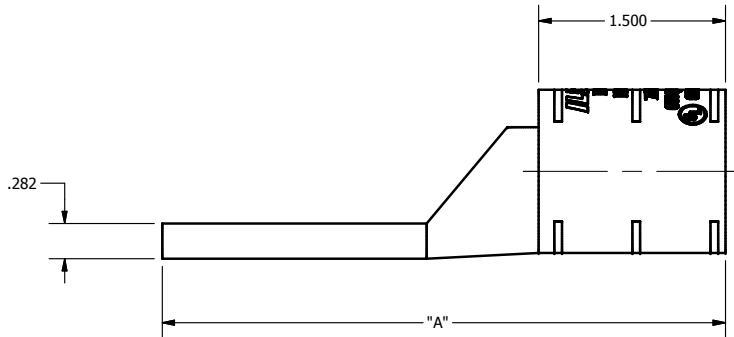

Catalog Number	"A"	"D"	"G"	TANG MARKING
CSWS-750-38	3.652	0.406	0.211	ILSCO, CSWS-750-38, DIE 106, 750 kcmil, 600 GHIM / 646 FLEX, UL, CSA
CSWS-750-12	3.652	0.562	0.265	ILSCO, C-750-12, 1/2, 750 kcmil, 600/646 FLEX, DIE 106, UL, CSA
CSWS-750-58	3.839	0.656	0.343	ILSCO, CSWS-750-58, 5/8, 750 kcmil, 600 GHIM / 646 FLEX, DIE 106, UL, CSA
CSWS-750-34	4.089	0.781	0.359	
CSWS-750-78	4.339	0.906	0.437	
CSWS-750-1	4.527	1.031	0.500	

THE INFORMATION CONTAINED WITHIN THIS DOCUMENT IS PROPRIETARY TO ILSCO AND MAY NOT BE DISCLOSED WITHOUT PRIOR WRITTEN CONSENT